

Please check the examination details below before entering your candidate information

Candidate surname

Other names

**Pearson Edexcel**  
**International**  
**Advanced Level**

Centre Number

Candidate Number

--	--	--	--	--

--	--	--	--

**Time** 1 hour 30 minutes

**Paper**  
**reference**

**WBI11/01**

**Biology**

**International Advanced Subsidiary / Advanced Level**  
**UNIT 1: Molecules, Diet, Transport and Health**

**You must have:**

Scientific calculator, ruler, HB pencil

Total Marks

## Instructions

- Use **black** ink or ball-point pen.
- **Fill in the boxes** at the top of this page with your name, centre number and candidate number.
- Answer **all** questions.
- Answer the questions in the spaces provided  
– *there may be more space than you need.*
- **Show all your working in calculations and include units where appropriate.**

## Information

- The total mark for this paper is 80.
- The marks for **each** question are shown in brackets  
– *use this as a guide as to how much time to spend on each question.*
- In questions marked with an **asterisk** (\*), marks will be awarded for your ability to structure your answer logically, showing how the points that you make are related or follow on from each other where appropriate.

## Advice

- Read each question carefully before you start to answer it.
- Try to answer every question.
- Check your answers if you have time at the end.
- Good luck with your examination.

Turn over ►

P65812A

©2021 Pearson Education Ltd.

1/1/1/1/1/1/1/



Pearson

Answer ALL questions. Write your answers in the spaces provided.

Some questions must be answered with a cross . If you change your mind about an answer, put a line through the box  and then mark your new answer with a cross .

1 Polysaccharides, lipids, nucleic acids and proteins are large molecules found in living organisms.

(a) Polymers are large molecules made of monomers. The table gives information about some of these polymers.

Complete the table by filling in the empty boxes with either the name of the monomer, the elements present in each monomer or the type of bond between monomers.

(4)

Polymer	Monomer	Elements present in monomer	Type of bond between monomers
polysaccharides	monosaccharide	..... ..... ..... ..... .....	glycosidic
nucleic acid	.....	carbon, hydrogen, oxygen, phosphorus and nitrogen	.....
protein	amino acid	..... ..... ..... ..... .....	peptide

DO NOT WRITE IN THIS AREA

DO NOT WRITE IN THIS AREA

DO NOT WRITE IN THIS AREA



DO NOT WRITE IN THIS AREA

DO NOT WRITE IN THIS AREA

DO NOT WRITE IN THIS AREA

(b) Triglycerides are lipids.

Describe how an unsaturated triglyceride is synthesised.

(3)

.....

.....

.....

.....

.....

.....

.....

.....

.....

.....

.....

**(Total for Question 1 = 7 marks)**



2 A person with diabetes has a blood glucose level that can be too high.

When the blood glucose level of a person without diabetes becomes too high, the liver stores glucose as a polysaccharide.

(a) Which polysaccharide does the liver store?

(1)

- A amylopectin
- B cellulose
- C glycogen
- D starch

(b) Blood glucose levels can become high following the digestion of carbohydrates.

Which of the following can be digested to release glucose?

(1)

- A both fructose and sucrose
- B both fructose and galactose
- C both galactose and lactose
- D both lactose and sucrose

(c) Diabetes is a risk factor for cardiovascular disease.

(i) One estimate is that there are 415 million people with diabetes in the world and that 46% of these people are undiagnosed.

Calculate the number of people who have undiagnosed diabetes.

(1)

Answer .....



(ii) There are two types of diabetes, Type I and Type II.

The treatment for Type I diabetes is different from the treatment for Type II diabetes, so it is important for a correct diagnosis to be made.

Diagnosis can be difficult, particularly in people aged between 20 and 40 years old.

A genetic screening method is now available for the diagnosis of diabetes.

Explain why doctors are more likely to screen individuals once they develop diabetes than use methods such as prenatal testing.

(3)

.....

.....

.....

.....

.....

.....

.....

.....

.....

.....

.....

**(Total for Question 2 = 6 marks)**

DO NOT WRITE IN THIS AREA

DO NOT WRITE IN THIS AREA

DO NOT WRITE IN THIS AREA



DO NOT WRITE IN THIS AREA

DO NOT WRITE IN THIS AREA

DO NOT WRITE IN THIS AREA

**BLANK PAGE**



**3** Stents are used in the treatment of atherosclerosis.

(a) The diagram shows how stents are positioned in a diseased coronary artery.

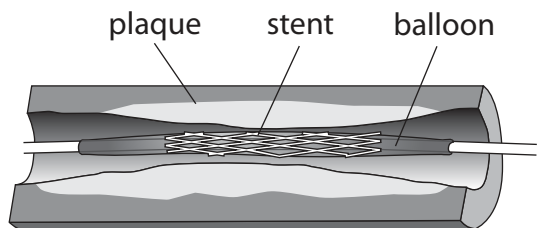

An uninflated balloon and narrow stent are inserted into the diseased coronary artery.

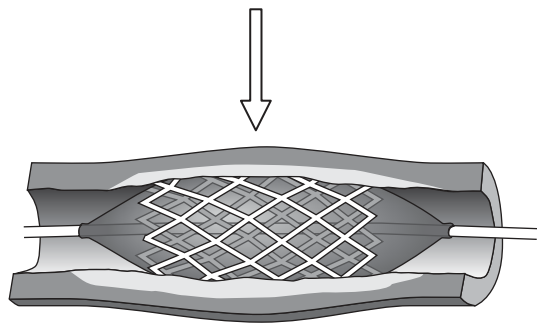

The balloon is inflated, expanding the stent.

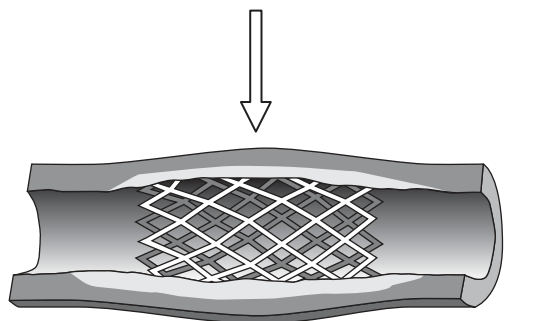

The balloon is deflated and removed, leaving the expanded stent in place.

Explain why a stent is used in the treatment of atherosclerosis in a coronary artery.

(3)

.....

.....

.....

.....

.....

.....

.....

.....

.....

.....

(b) Inserting a stent can damage the artery.

This damage can result in stent thrombosis if the blood clotting process is stimulated.

A study looked at the damage caused by two different types of stent, stent **A** and stent **B**.

The graph shows the incidence of stent thrombosis found in this study.

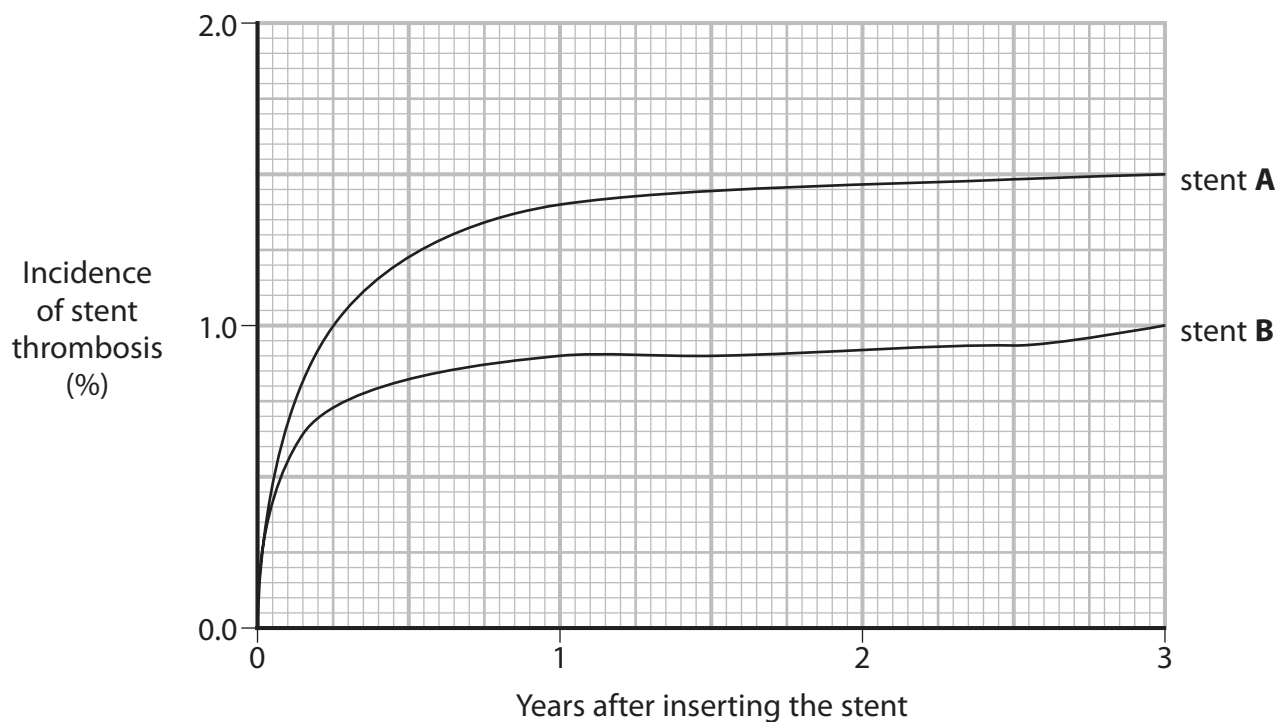

- (i) In this study, 800 patients had stent **A** inserted and 400 patients had stent **B** inserted.

Calculate the difference in the number of patients who developed stent thrombosis three years after inserting the stent.

(2)

Answer .....





(ii) State how the formation of a blood clot in the coronary artery could cause the death of the patient.

(1)

(iii) Which components of the blood clotting process are enzymes in their active form?

(1)

- A prothrombin and thromboplastin only
- B prothrombin and thrombin only
- C prothrombin, thrombin and thromboplastin
- D thrombin and thromboplastin only

(iv) Which components of the blood clotting process are soluble in blood plasma?

(1)

- A fibrin and fibrinogen
- B fibrin and thromboplastin
- C fibrinogen and thromboplastin
- D fibrinogen only

(v) Stent **B** contains a drug to prevent stent thrombosis.

Suggest one type of drug that could be used in stent **B**.

(1)

**(Total for Question 3 = 9 marks)**

DO NOT WRITE IN THIS AREA

DO NOT WRITE IN THIS AREA

DO NOT WRITE IN THIS AREA



- 4 Phenylthiocarbamide (PTC) is a chemical that has a very bitter taste to some individuals (tasters).

The ability to taste PTC is determined by a gene that codes for a bitter-taste receptor on the tongue.

The pedigree diagram shows some of the tasters and non-tasters in a family.

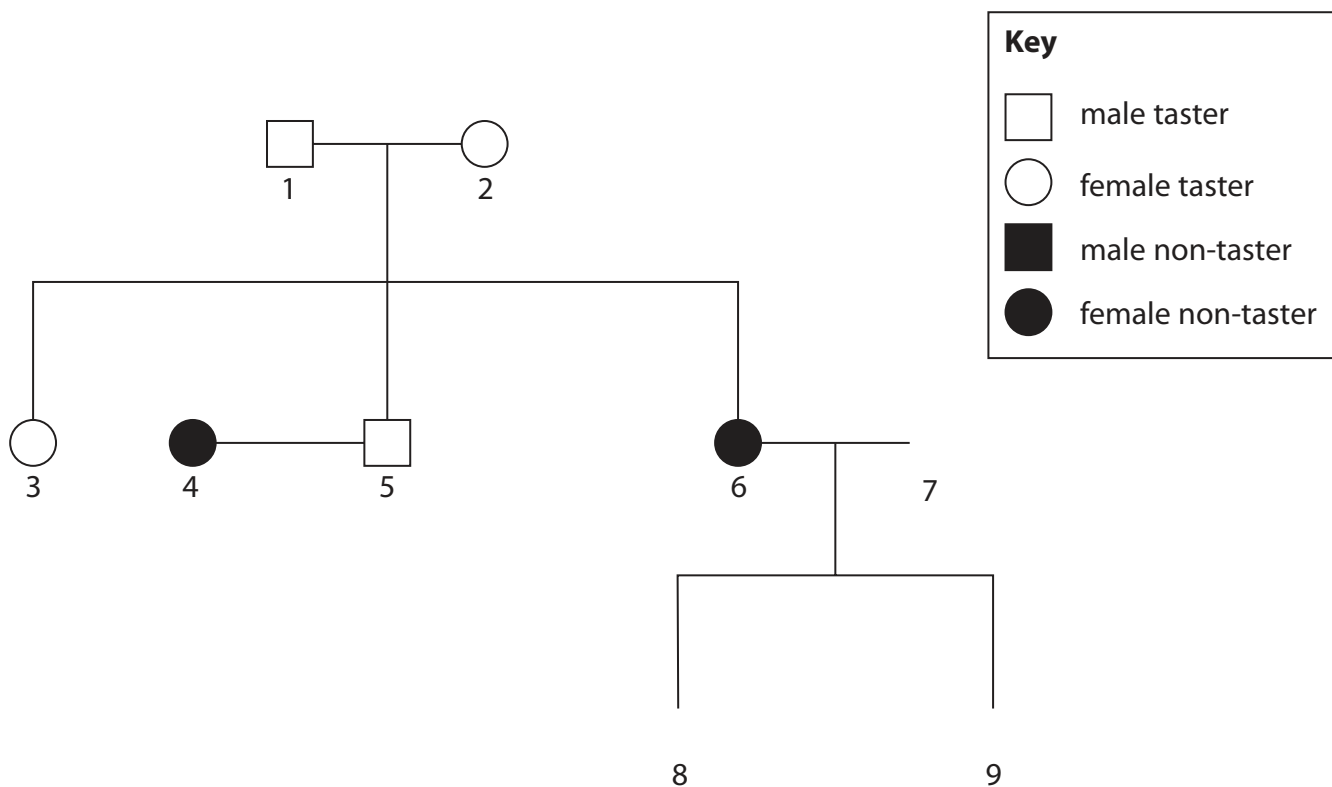

- (a) Complete the diagram to show the following information:

(1)

- individual 7 as a male taster
- individual 8 as a male non-taster
- individual 9 as a female taster.



DO NOT WRITE IN THIS AREA

DO NOT WRITE IN THIS AREA

DO NOT WRITE IN THIS AREA

(b) Describe the difference between each of the following pairs of terms, using the information in the pedigree diagram to illustrate your answer.

(i) Gene and allele

(2)

.....

.....

.....

.....

.....

.....

(ii) Genotype and phenotype

(2)

.....

.....

.....

.....

.....

.....

(c) Explain which is the dominant allele.

Use the information in the pedigree diagram to support your answer.

(2)

.....

.....

.....

.....

.....

.....



DO NOT WRITE IN THIS AREA

DO NOT WRITE IN THIS AREA

DO NOT WRITE IN THIS AREA

(d) Explain why this gene is unlikely to be located on the X chromosome.

Use the information in the pedigree diagram to support your answer.

(2)

.....

.....

.....

.....

.....

.....

.....

**(Total for Question 4 = 9 marks)**



DO NOT WRITE IN THIS AREA

DO NOT WRITE IN THIS AREA

DO NOT WRITE IN THIS AREA

**BLANK PAGE**



P 6 5 8 1 2 A 0 1 3 3 2

5 People with cystic fibrosis produce very thick, sticky mucus.

Cystic fibrosis is caused by mutations in a gene coding for the CFTR protein.

(a) Explain why a mutation in this gene results in the production of very thick, sticky mucus.

(3)

.....

.....

.....

.....

.....

.....

.....

.....

.....

.....

.....

DO NOT WRITE IN THIS AREA

DO NOT WRITE IN THIS AREA

DO NOT WRITE IN THIS AREA



(b) The diagram shows some health problems associated with cystic fibrosis, in a female.

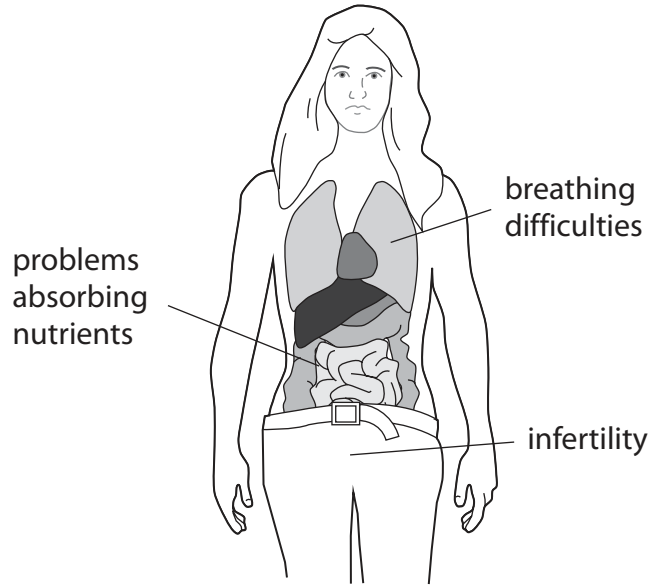

Explain why very thick, sticky mucus results in these health problems.

(5)

.....

.....

.....

.....

.....

.....

.....

.....

.....

.....

.....

.....

.....

.....

.....

.....

.....

.....

.....

.....

.....

.....

DO NOT WRITE IN THIS AREA

DO NOT WRITE IN THIS AREA

DO NOT WRITE IN THIS AREA



- (c) The graph shows the correlation between the concentration of chloride ions in sweat and the level of function of the CFTR protein.

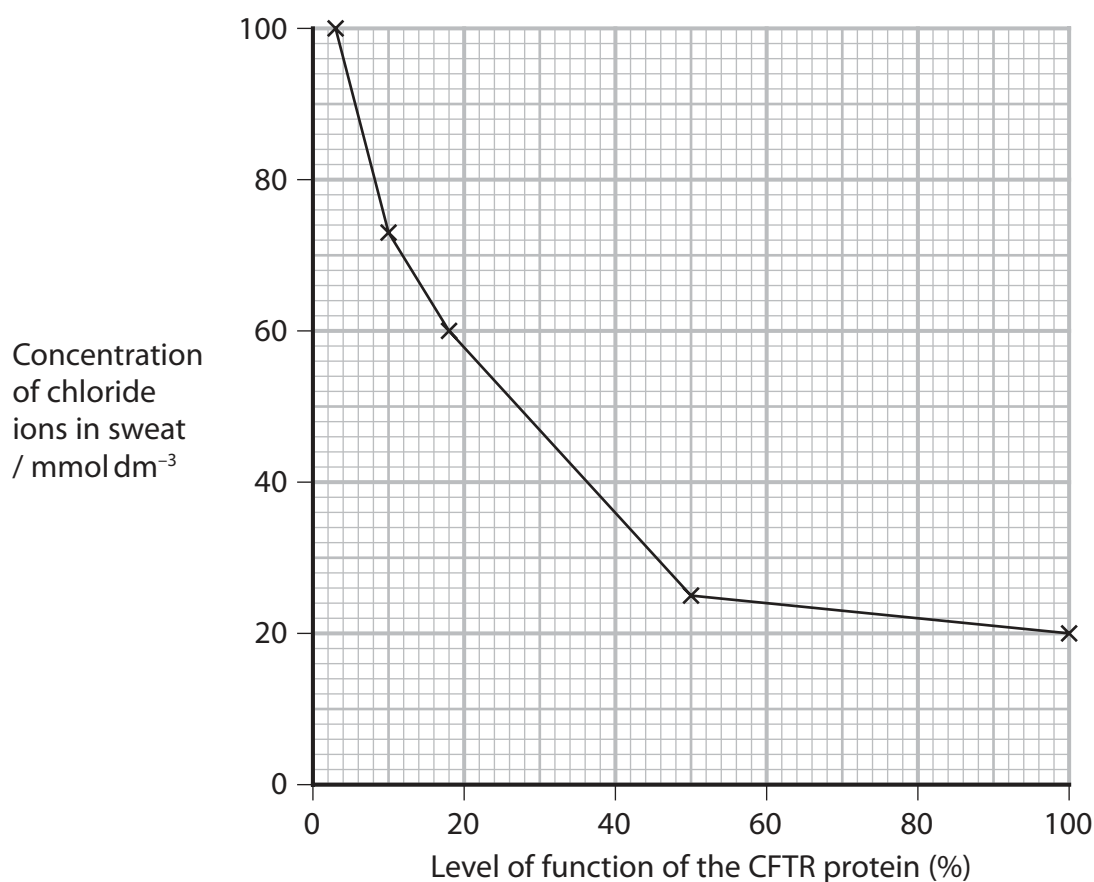

Individuals diagnosed with cystic fibrosis have a level of function of the CFTR protein of 18% or less.

- (i) Which is the change in concentration of chloride ions in the sweat of an individual when the level of function of CFTR protein decreased from 100% to 18%?

(1)

- A** 15 mmol dm<sup>-3</sup>
- B** 35 mmol dm<sup>-3</sup>
- C** 40 mmol dm<sup>-3</sup>
- D** 80 mmol dm<sup>-3</sup>





(ii) Cystic fibrosis results from different mutations in the CFTR gene.

Explain how the graph provides evidence that cystic fibrosis results from different mutations in the CFTR gene.

(2)

.....

.....

.....

.....

.....

.....

.....

**(Total for Question 5 = 11 marks)**

DO NOT WRITE IN THIS AREA

DO NOT WRITE IN THIS AREA

DO NOT WRITE IN THIS AREA



6 Obesity increases the risk of cardiovascular disease (CVD).

Body mass index (BMI), waist-to-hip ratio (WHR) and skinfold thickness are indicators of obesity.

- (a) The table shows some measurements taken from two females, female **J** and female **K**.

Female	Height / cm	Mass / kg	Waist / cm	Hips / cm	BMI	WHR
<b>J</b>	155	59.1	80	100	25	0.80
<b>K</b>	155			125	36	0.80

- (i) Calculate the waist size of female **K**.

(1)

Answer ..... cm

- (ii) The formula for calculating BMI is:

$$\text{BMI} = \frac{\text{mass in kg}}{(\text{height in m})^2}$$

Calculate the mass of female **K**, using the data in the table.

(3)

Answer ..... kg



(iii) Comment on the risk of developing CVD in these two women.

(2)

(iv) The diagram shows how the waist and hip measurements should be taken, using a tape measure.

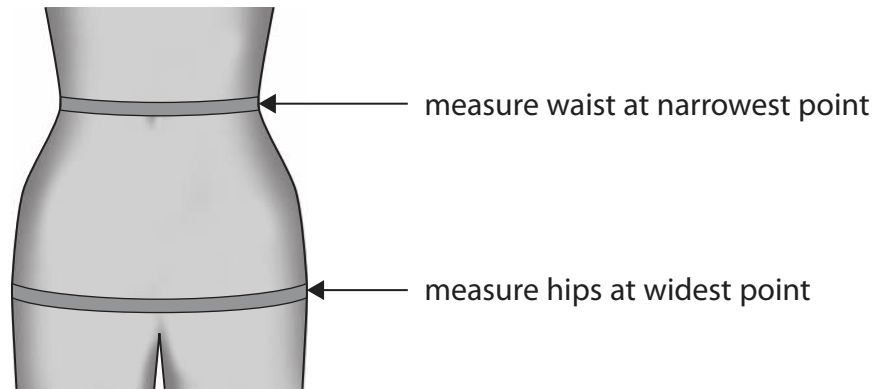

Explain how the way a person takes these measurements could produce an underestimate of their risk of CVD.

(2)

DO NOT WRITE IN THIS AREA

DO NOT WRITE IN THIS AREA

DO NOT WRITE IN THIS AREA



- (b) The diagram shows how a skinfold thickness measurement is taken over the triceps muscle at the back of the arm.

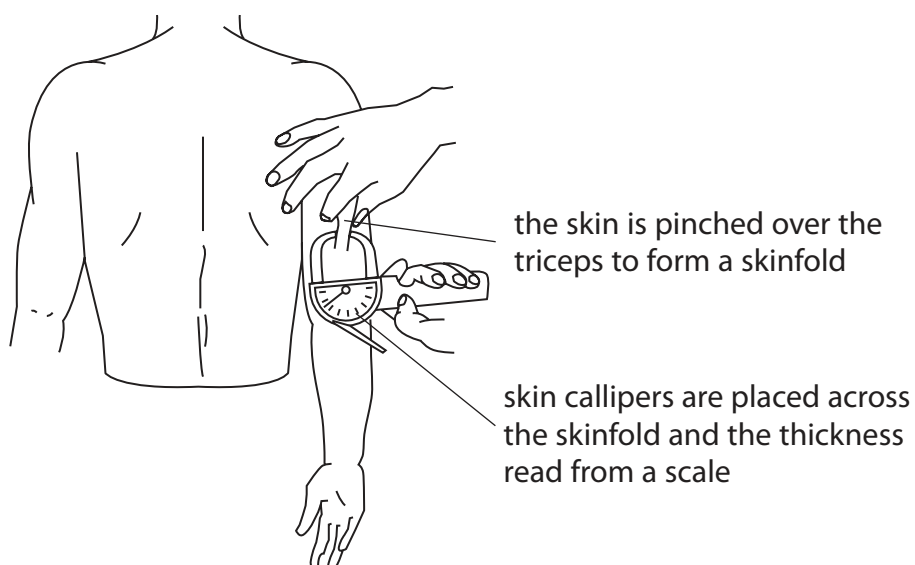

Skinfold thickness measures the thickness of the layer of fat under the skin.

Measurements are taken from several sites on the body.

The table shows the skinfold thickness at four sites on a 42-year-old female.

Site	Skinfold thickness / a.u.
over the biceps at the front of the arm	0.63
over the triceps at the back of the arm	0.82
under the shoulder blade at the back of the neck	0.65
above the hip bone at the side of the body	0.82

- (i) Suggest **two** reasons why the skinfold thickness values are different at each site on the body.

Assume that the skin callipers have been used correctly.

(2)

.....

.....

.....

.....

.....

.....

.....



(ii) The table shows a body fat interpretation chart.

The values in the table are the means of the four skinfold thickness measurements.

Age	Level of body fat			
	Low	Moderate	High	Very high
20 to 29	<0.71	0.71 to 0.77	0.78 to 0.82	>0.82
30 to 39	<0.72	0.72 to 0.78	0.79 to 0.84	>0.84
40 to 49	<0.73	0.73 to 0.79	0.80 to 0.87	>0.87
50 to 59	<0.74	0.74 to 0.81	0.82 to 0.88	>0.88

Determine the level of body fat of this female.

(1)

Answer .....

**(Total for Question 6 = 11 marks)**

DO NOT WRITE IN THIS AREA

DO NOT WRITE IN THIS AREA

DO NOT WRITE IN THIS AREA



7 A number of diseases are associated with lifestyle risk factors.

Some of these risk factors cause mutations.

(a) Mutations can give rise to cancer.

State the meaning of the term **mutation**.

(1)

(b) Exposure to ultraviolet light is associated with the development of skin cancer.

The graphs show the incidence of skin cancer in males and females in one country in the Far East, from 2000 to 2005.

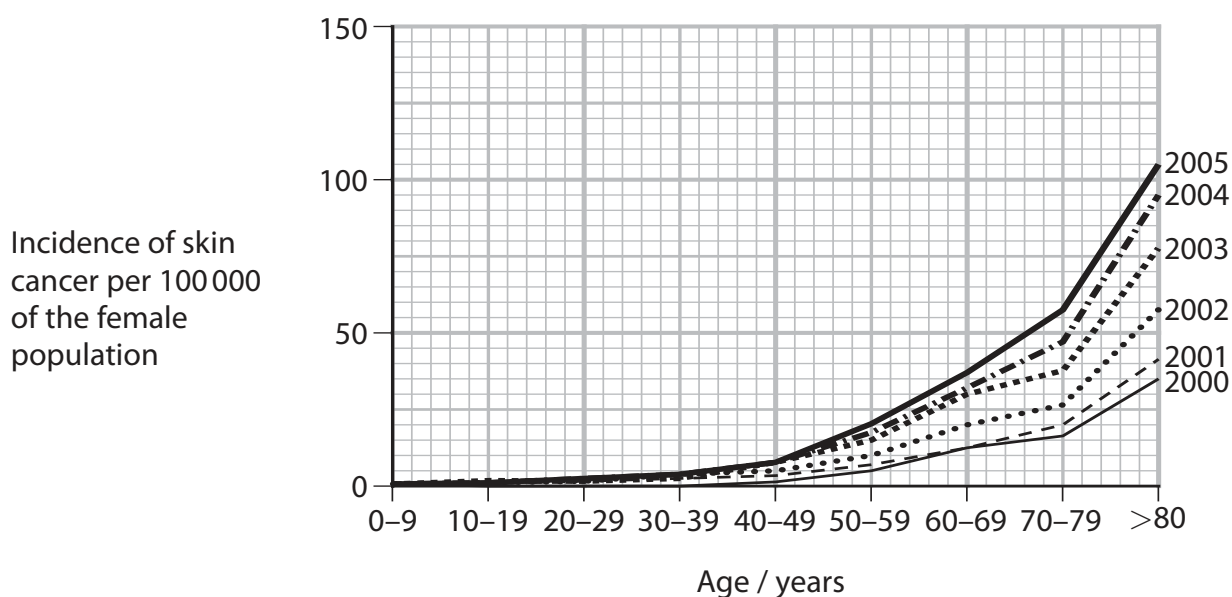
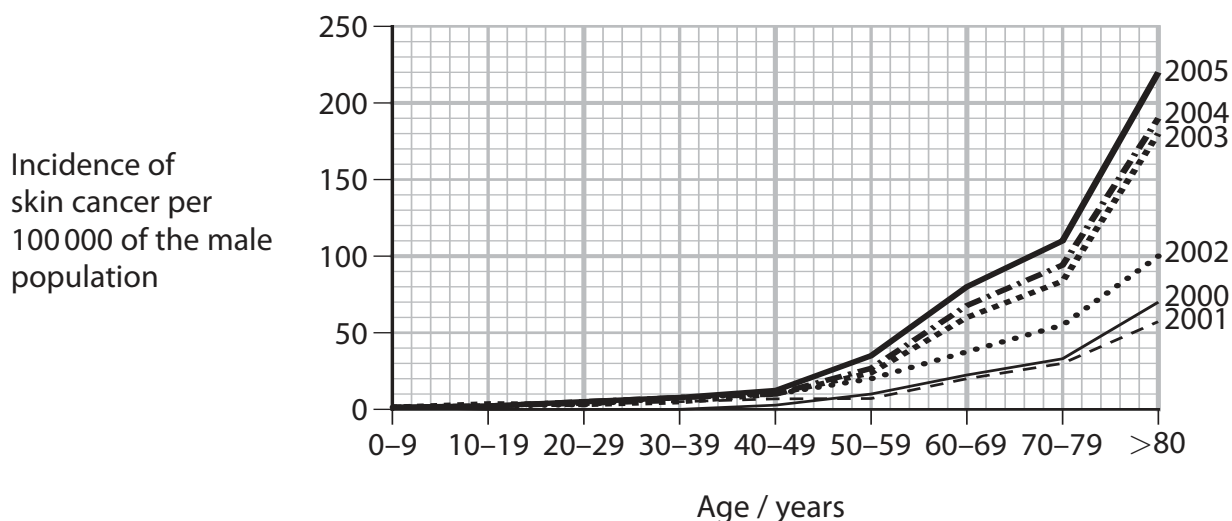

(i) The graphs show some correlations.

State the meaning of the term **correlation**.

(1)

(ii) Describe the correlations shown by these graphs.

(3)

(iii) Suggest a reason for each of the correlations shown by these graphs.

(3)

DO NOT WRITE IN THIS AREA



P 6 5 8 1 2 A 0 2 3 3 2

\*(c) The table shows some information from a study of the incidence of emphysema in smokers and non-smokers.

Information	Males	Females
Number of individuals in the study	25	25
Mean age when diagnosed / years	53.1	54.2
Range of ages when diagnosed / years	32 to 77	34 to 68
Number of smokers	5	6
Number of non-smokers	20	19
Number of smokers with emphysema	1	6
Number of non-smokers with emphysema	0	0

Criticise the design of this study.

(6)

.....

.....

.....

.....

.....

.....

.....

.....

.....

.....

.....

.....

.....

.....

.....

.....

.....

.....

.....

.....

.....

.....





DO NOT WRITE IN THIS AREA

DO NOT WRITE IN THIS AREA

DO NOT WRITE IN THIS AREA

(Total for Question 7 = 14 marks)



P 6 5 8 1 2 A 0 2 5 3 2

8 The structure of the cell membrane affects the properties of the cell membrane.

The diagram shows the structure of part of a cell membrane.

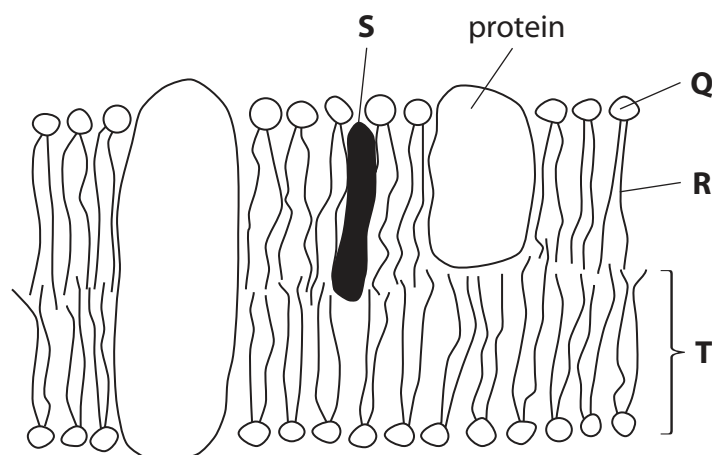

(a) (i) The magnification of this diagram is  $1 \times 10^7$ .

The structure labelled **T** is 2 units long.

What is this unit?

- A** cm
- B** mm
- C**  $\mu\text{m}$
- D** nm

(1)

(ii) Which structures contain a phosphate group?

- A** **Q** and **R**
- B** **Q** and **T**
- C** **R** and **S**
- D** **S** and **T**

(1)

(iii) Which ratio of the structures affects the fluidity of this membrane?

- A** **Q:T**
- B** **R:Q**
- C** **R:T**
- D** **S:T**

(1)



(b) Explain the role of the primary structure in determining the properties of the protein labelled in the diagram.

(4)

.....

.....

.....

.....

.....

.....

.....

.....

.....

.....

.....

.....

.....

.....

.....

DO NOT WRITE IN THIS AREA

DO NOT WRITE IN THIS AREA

DO NOT WRITE IN THIS AREA



\*(c) The diagram and table give information about some molecules found inside and outside a cell.

Molecule	Key	Description
E	○	small dipolar molecule consisting of two hydrogen atoms and one oxygen atom
F	●	large polar molecule
G	○	non-polar molecule
H	●	small polar molecule

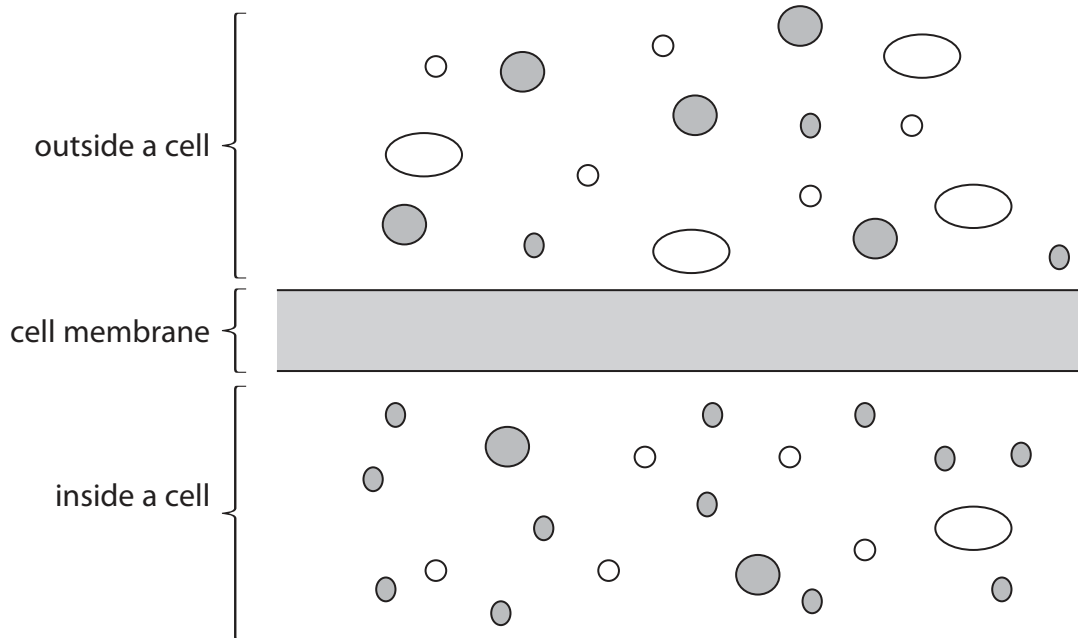

DO NOT WRITE IN THIS AREA

DO NOT WRITE IN THIS AREA

DO NOT WRITE IN THIS AREA



Explain why each of these molecules **enters** the cell by a different mechanism.

Use the information in the table and the diagram to support your answer.

(6)

DO NOT WRITE IN THIS AREA

DO NOT WRITE IN THIS AREA

DO NOT WRITE IN THIS AREA

---

**(Total for Question 8 = 13 marks)**

---

**TOTAL FOR PAPER = 80 MARKS**



DO NOT WRITE IN THIS AREA

DO NOT WRITE IN THIS AREA

DO NOT WRITE IN THIS AREA

**BLANK PAGE**



DO NOT WRITE IN THIS AREA

DO NOT WRITE IN THIS AREA

DO NOT WRITE IN THIS AREA

**BLANK PAGE**



DO NOT WRITE IN THIS AREA

DO NOT WRITE IN THIS AREA

DO NOT WRITE IN THIS AREA

**BLANK PAGE**

